



Service Guide

3685-A 3685-G
 3685-B 3685-J
 3685-F 3685-K
 3685-M
 3686-B 3686-F

Mechanical-Metered Control Valve

Description

These mechanical-metered valves are designed to dispense and measure quantities of fluid lubricants.

All models are equipped with a dual-range face dial and two pointers. The outer pointer indicates delivery up to 4 quarts (liters). The inner pointer indicates delivery up to 16 quarts (10 liters).

A totalizer keeps a lifetime record of the amount dispensed.

These models are equipped with an inlet swivel and an internal filter screen to prevent damaging contaminants from entering the meter.

Operation

Depress the lever to dispense fluid. For a large quantity delivery, squeeze the lever fully until the latch catches. Press the knurled button to disengage the latch.

After each delivery turn the pointers counterclockwise to reset to zero.

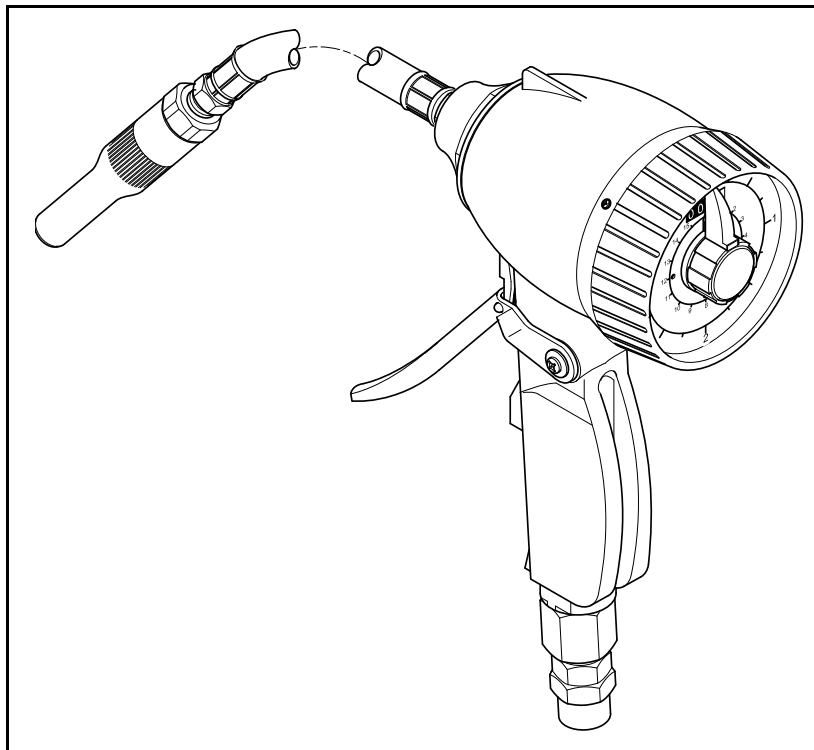

Figure 1 Mechanical-Metered Control Valve (Model 3685-A Shown)

CAUTION

Do not turn the pointers clockwise. Damage can occur.

Valve Model	Fluid Metered	Extension	Nozzle Type	Inlet	Register Units		Accuracy	Maximum Pressure		
					Current	Totalizer		psi	Bar	
3685-A	Oil	Flexible	Non-Drip Automatic	1/2 " NPTF (f)	Liter	Liter	+ / - 0.65 %	1000	69	
3685-B		Rigid			Gallon					
3685-F		Flexible	Non-Drip Manual		Quart	Quart				
3685-G						Rigid				Gallon
3685-J						Flexible				Non-Drip Automatic
3685-K		Rigid								
3685-M		ATF	Flexible		Non-Drip Manual	Quart				Gallon
3686-B										
3686-F										

Table 1 Mechanical-Metered Control Valve Model 3685 Series and 3686 Series

Alemite LLC
 167 Rowland Drive, Johnson City, Tennessee 37601
 www.alemite.com

Copyright © 2003 by Alemite LLC

This document contains confidential information that is the property of Alemite LLC and is not to be copied, used, or disclosed to others without express written permission.

SER 3685-A
 Revision (11-08)

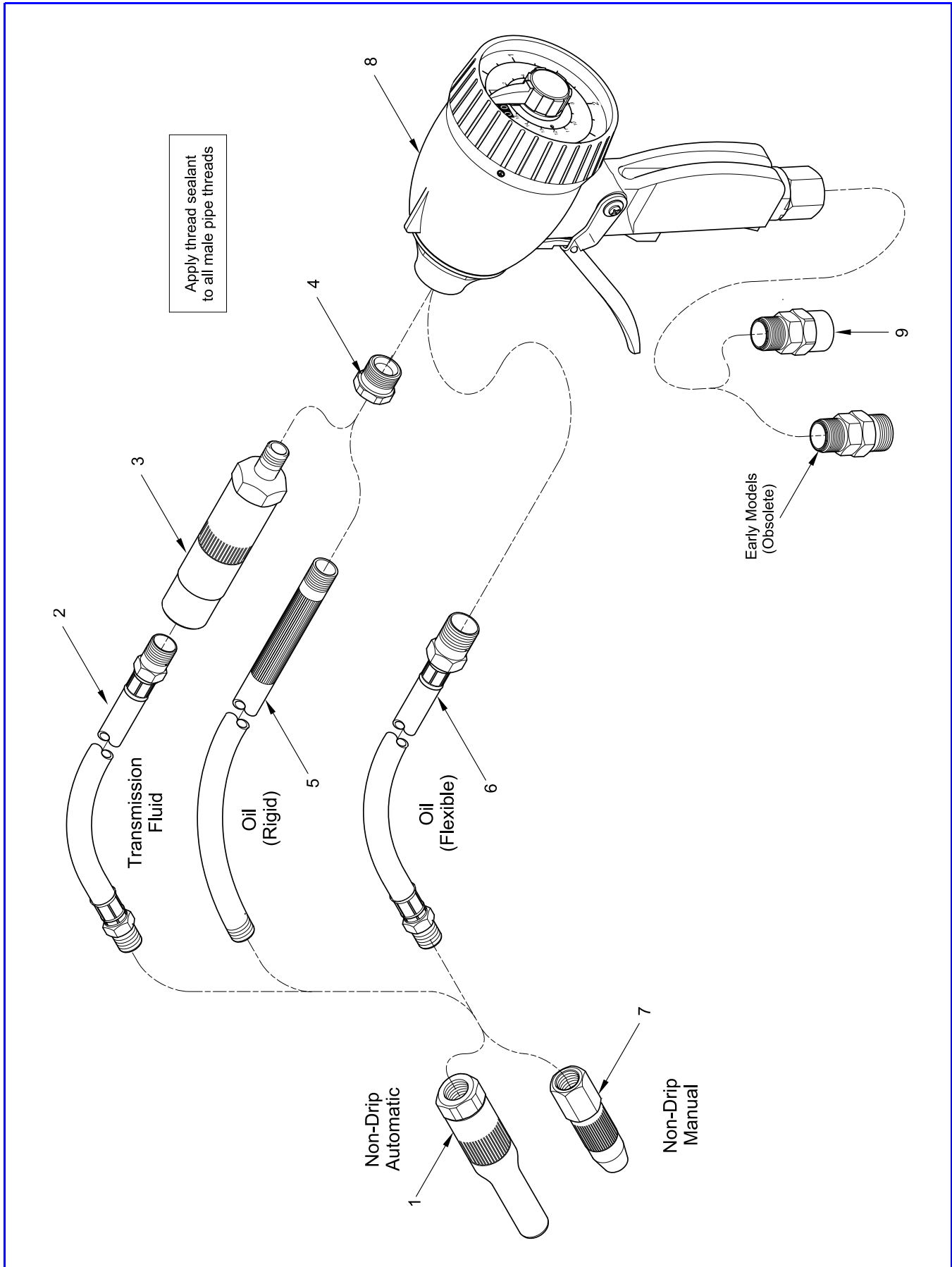

Figure 2-A Mechanical-Metered Control Valve Model 3685 Series and 3686 Series - Exploded View (Sheet 1 of 2)

Item No.	Part No.	Description	Control Valve									Qty	Notes	Numeric Order Part # (Item #)
			3685-A	3685-B	3685-F	3685-G	3685-J	3685-K	3685-M	3686-B	3686-F			
1	B339800	Nozzle Assembly, Automatic	●	●					●	●		1		51891 (4)
2	317860-1	Hose, 1/4 " NPTF (m) x 1/4 " NPTF (m)									●	1		317860-1 (2)
3	321203	Filter Assembly (40-Micron)									●	1	See Figure 3	321203 (3)
4	51891	Bushing, 1/2 " NPTF (m) x 1/4 " NPTF (f)		●				●			●	1		337739 (8)
5	337976	Extension		●				●				1		337976 (5)
6	338709	Hose, 1/2 " NPTF (m) x 1/4 " NPTF (m)	●		●				●			1		338709 (6)
7	339084	Nozzle Assembly, Non-Drip Manual			●			●				1		339084 (7)
8		Meter Assembly (Quart w/ Gallon Totalizer)		●				●			●	1		339137 (8)
		Meter Assembly (Liter w/ Liter Totalizer)	●									1	See Figure 2-B	339651 (9)
		Meter Assembly (Quart w/ Quart Totalizer)										1		339654 (8)
9	339651	Swivel Assembly, 1/2 " NPTF (m) x 1/2 " NPTF (f)	●	●	●	●	●	●	●	●	●	1		B339800 (1)

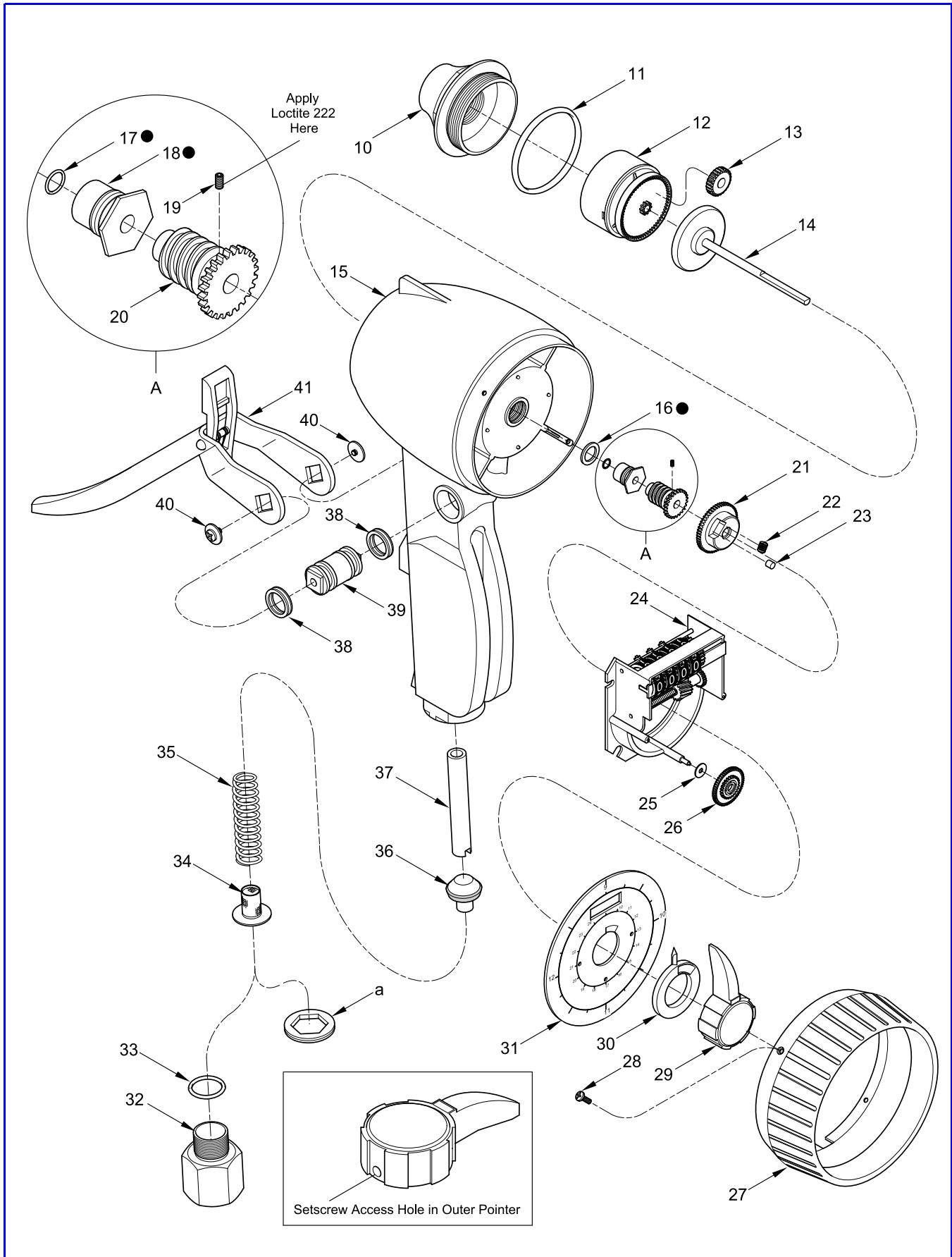

Figure 2-B Mechanical-Metered Control Valve Model 3685 Series and 3686 Series - Exploded View (Sheet 2 of 2)

Item No.	Part No.	Description	Qty	Notes	Numeric Order Part # (Item #)
10		Cap	1		(13)
11	393307-60	O-Ring (Buna-N)	1		(15)
12	393307-55	Chamber and Piston Assembly	1	Except Models 3685-A,-M	393307-14 (22)
		Chamber and Piston Assembly (Liter)	1	Models 3685-A,-M Only	393307-15 (23)
13		Gear, Planetary	1	Included w/ item 12	<i>393307-19</i> (25)
14	393307-141	Spindle and Gear Assembly	1	Except Models 3685-A,-M	393307-41 (38)
		Spindle and Gear Assembly (Liter)	1	Models 3685-A,-M Only	393307-42 (37)
15		Housing	1		393307-45 (35)
16	393307-128	Washer (Buna-N)	1	●	393307-46 (a)
17	393307-130	O-Ring (Buna-N)	1	●	393307-55 (12)
18		Nut, Gland	1	●	<i>393307-56</i> (12)
19		Setscrew	1		393307-60 (11)
20		Gear, Worm (Quart w/ Quart Totalizer)	1		<i>393307-62</i> (10)
		Gear, Worm (Quart w/ Gallon Totalizer)	1		<i>393307-105</i> (21)
		Gear, Worm (Liter w/ Liter Totalizer)	1		393307-106(26)
21		Cam	1		393307-107(30)
22	393307-14	Spring	1		<i>393307-108</i> (20)
23	393307-15	Roller	1		393307-109(41)
24	393307-159	Register Assembly	1	Except Models 3685-A,-M	393307-110(39)
	393307-160	Register Assembly (Liter)	1	Models 3685-A,-M Only	393307-120(31)
25		Washer	1		<i>393307-121</i> (20)
26	393307-106	Gear, Pointer	1	Except Models 3685-A,-M	393307-125(36)
		Gear, Pointer (Liter)	1	Models 3685-A,-M Only	393307-126(34)
27	393307-163	Shroud	1		393307-128(16)
28		Screw	4		<i>393307-129</i> (28)
29	393307-162	Pointer, Outer (w/ Setscrew)	1		393307-130(17)
30	393307-107	Pointer, Inner	1		393307-132(40)
31	393307-120	Dial (Quart w/Gallon Totalizer)	1	Except Models 3685-A,-G,-M	<i>393307-133</i> (18)
	393307-184	Dial (Liter w/ Liter Totalizer)	1	Models 3685-A,-M Only	393307-141(14)
	393307-198	Dial (Quart w/ Quart Totalizer)	1	Model 3685-G Only	<i>393307-142</i> (14)
32	393307-170	Adapter, 1/2 " NPTF (f)	1		<i>393307-158</i> (19)
33	393307-168	O-Ring	1		393307-159(24)
34	393307-126	Screen, Filter	1		393307-160(24)
35	393307-45	Spring	1		393307-162(29)
36	393307-125	Valve Assembly (Buna-N)	1		393307-163(27)
37	393307-42	Sleeve, Valve	1	Included w/ item 36	393307-168(33)
38	393307-41	Quad-Ring (Buna-N)	2		393307-170(32)
39	393307-110	Cam	1		393307-184(31)
40	393307-132	Screw	2		<i>393307-185</i> (26)
41	393307-109	Lever Assembly	1		<i>393307-186</i> (20)
Component Used on Early Models (without Item Number 32)					393307-198(31)
a	393307-46	Retainer, Spring	1		

Legend:Part numbers left blank (or in *italics*) are not available separately

● designates a repair kit item

Repair Kit

Part No.	Kit Symbol	Description
393307-134	●	Kit, Packing Gland

Overhaul

Prior to performing any maintenance procedure, the following safety precautions must be observed. Personal injury may occur.



WARNING

Do not use halogenated hydrocarbon solvents such as methylene chloride or 1,1,1-trichloroethane in this valve. An explosion can result when aluminum and/or zinc-plated parts in the valve come in contact with halogenated hydrocarbon solvents.

Release all pressure within the system prior to performing any overhaul procedure.

- **Disconnect the air supply line from the pump motor.**
- **Into an appropriate container, operate the control valve to discharge remaining pressure within the system.**

Never point a control valve at any portion of your body or another person. Accidental discharge of pressure and/or material can result in injury. Read each step of the instructions carefully. Make sure a proper understanding is achieved before proceeding.

Disassembly

NOTE: Refer to **Figures 2-A, 2-B** and **3** for component identification on all overhaul procedures.

Metered Control Valve

NOTE: The following procedures pertain to all models of metered control valves.

1. Unscrew the extension assembly from Meter Assembly (**8**).
2. Separate the components of the extension assembly.

Shroud and Register Assembly

3. Unscrew Screws (**28**) that secure Shroud (**27**) to Housing (**15**)
 - Remove the Shroud from the Housing.
4. Blow low pressure air into the valve's inlet to rotate the Outer Pointer to the 11 o'clock position.

5. Turn Outer Pointer (**29**) counterclockwise until the access hole in the Pointer lines up with the setscrew.
 - See **Figure 2-B** inset.
6. Loosen the setscrew that secures the Outer Pointer to Spindle and Gear Assembly (**14**).
 - Remove the Outer Pointer from the Spindle and Gear Assembly.
7. Remove Inner Pointer (**30**) Dial (**31**) and Cam (**21**) as an assembly from the Spindle and Gear Assembly.
 - Push the Cam Assembly from the Inner Pointer and Dial to separate components.
8. Carefully remove Spring (**22**) and Roller (**23**) from the Cam as required.
9. Remove Pointer Gear (**26**) and Washer (**25**) from Register Assembly (**24**).
10. Remove the Register Assembly from the Housing.

HINT: Compress the spring with the nylon gear to clear Worm Gear (**20**).
11. Loosen Setscrew (**19**) that secures Worm Gear (**20**) to the Spindle and Gear Assembly.
 - Remove the Worm Gear from the Spindle and Gear Assembly.

Metering Mechanism Assembly

12. Unscrew Cap (**10**) from the Housing.
 - Remove O-Ring (**11**) from the Cap.
13. Remove Chamber and Piston Assembly (**12**), Planetary Gear (**13**), and the Spindle and Gear Assembly from the Housing.
14. Remove Gland Nut (**18**) from the Housing.
 - Remove O-Ring (**17**) from the Gland Nut.
15. Remove Washer (**16**) from the Housing.

Inlet Swivel, Valve, and Lever Assembly

16. Unscrew Swivel Assembly (**9**) from Adapter (**32**).
17. Unscrew the Adapter from the Housing.
 - Remove O-Ring (**33**) from the Adapter.
18. Remove Screen (**34**), Spring (**35**), Valve Assembly (**36**), and Valve Sleeve (**37**) from the Housing.
19. Remove Screws (**40**) that secure Lever Assembly (**41**) to Cam (**39**).
 - Remove the Lever Assembly from the Cam.
20. Push the Cam from the Housing.
 - Remove Quad Rings (**38**) from the Cam.

Transmission Fluid Filter

1. Unscrew Spring and Adapter Assembly (46) from Body (42).
2. Remove O-Ring (45) from the Spring and Adapter Assembly.
3. Remove Stud (44) from the Body.
4. Remove Filter Tube (43) from the Body.

Clean and Inspect

1. Clean all metal parts in cleaning solvent. The solvent should be environmentally safe.
2. Inspect all parts for wear and/or damage.
 - Replace as necessary.
3. Closely inspect the mating surfaces of all components for any imperfections. Ensure a smooth and clean contact is obtained when assembled.

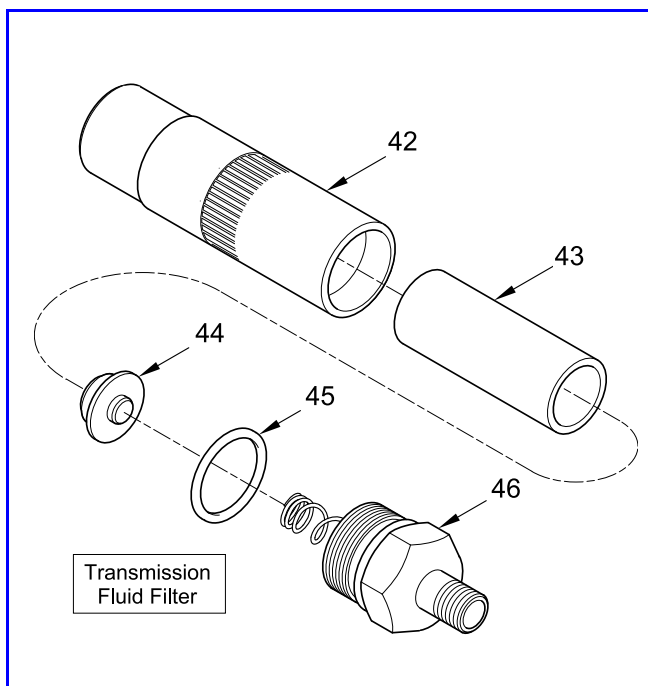

Item No.	Part No.	Description	Qty
42		Body	1
43	321191	Tube, Filter	1
44		Stud	1
45	X171001-14	O-Ring, 3/4 " ID x 15/16 " OD	1
46		Spring and Adapter Assembly	1

Legend:
 Part numbers left blank are not available separately
 Part number with an X prefix indicates a quantity of ten (10)

Figure 3 Filter Assembly 321203 - Exploded View

Assembly

NOTE: Prior to assembly, certain components require lubrication. Refer to **Table 2** for details.

Metered Control Valve

Metering Mechanism Assembly

1. Install and seat Washer (16) into the head of Housing (15).
2. Install O-Ring (17) into Gland Nut (18).
3. Screw the Gland Nut into the Housing.
 - Tighten the Gland Nut securely.
4. Position Chamber and Piston Assembly (12) gear end upward.
5. Install Planetary Gear (13) into the Chamber and Piston Assembly.
6. Position Spindle and Gear Assembly (14) onto the Chamber and Piston Assembly.
7. With the Spindle and Gear Assembly pointed upward, install the entire subassembly into the Housing.
 - Use care passing the O-Ring.

HINT: Rotate the Spindle and Gear Assembly so the flat of the shaft points between the posts of the Register Assembly. This aids in the installation of the Worm Gear.

CAUTION

Make sure the subassembly does not shift during installation or once installed. Damage to the Gears can occur.

8. Install O-Ring (11) onto Cap (10).
9. Screw the Cap into the Housing.
 - Tighten the Cap to 35 ft. lbs. (47 Nm).

Item No.	Description
11	O-Ring
16	Washer
17	O-Ring
33	O-Ring
38	Quad-Ring
45	O-Ring, 3/4 " ID x 15/16 " OD

Table 2 Components Lubricated in Clean Oil

Register Assembly

10. Install Register Assembly (24) onto the Housing
 - Make sure the Register seats on the four pins.
11. Install Setscrew (19) [with Loctite 222] into the Worm Gear.
12. Install Worm Gear (20) [spur gear upward] onto the shaft of the Spindle and Gear Assembly.
 - Make sure the Worm Gear's setscrew points toward the flat on the Spindle and Gear Assembly.
 - Check to ensure the gear meshes properly with the Register's gear.
13. Install Washer (25) onto the bottom post of the Register Assembly.
14. Install Pointer Gear (26) [flat surface downward] onto the Washer.

IMPORTANT: Make sure the Gears mesh evenly.

15. Move the Worm Gear [straight upward or downward] as required so its gear wheel meshes evenly with the Pointer Gear.
 - Tighten the Setscrew securely.

Dial-Cam-Pointers

16. Install Dial (31) onto Cam (21).
17. Install and seat Inner Pointer (30) [spring downward] onto the Cam.
18. Install Roller (23) into the Cam.

IMPORTANT: Make sure Spring (22) is against right-angled end of notch in Cam.

- See **Figure 2-B**.

19. Install Spring (22) into the Cam.

IMPORTANT: Make sure the three holes on the Dial engage with the Register's posts.

20. Install and seat the Cam, Dial, and Inner Pointer assembly onto the shaft of the Spindle and Gear Assembly.
21. Install the setscrew loosely into Outer Pointer (29) as required.
 - Make sure only a few threads are engaged.

IMPORTANT: The Outer Pointer's setscrew must point toward the flat on the Spindle and Gear Assembly.
22. Install the Outer Pointer [setscrew toward flat] onto the shaft of the Spindle and Gear Assembly.
 - Tighten the Setscrew securely.

23. Turn the Outer Pointer counterclockwise.
 - Set both Pointers to zero.
24. Install Shroud (27) [notch downward] onto the Housing.
25. Install Screws (28) that secure the Shroud to the Housing.
 - Tighten each Screw securely.

Lever Assembly

26. Install Quad Rings (38) onto each end of Cam (39).
27. Install the Cam into the Housing.
 - Use care passing the Quad Rings.
28. Install Lever Assembly (41) onto the Cam.
 - Reposition the Cam as required to ensure the Lever Assembly properly meshes.
29. Install Screws (40) that secure the Lever Assembly to the Cam.
 - Tighten the Screws securely.

Valve and Inlet Swivel Assembly

30. Install Valve Sleeve (37) [unslotted end first] into the Housing.
31. Install Valve Assembly (36) [stem first] into the small end of Spring (35).
32. Install the Valve Assembly and Spring horizontally into the Housing.
 - Make sure the Valve Assembly does not shift.
33. Install Screen (34) into the Spring.
34. Install O-Ring (33) onto the Adapter (32).
35. Screw the Adapter into the Housing.
 - Tighten the Adapter to 20 ft. lbs. (26 Nm).
36. Screw Swivel Assembly (9) [with thread sealant] into the Adapter.
 - Tighten the Swivel Assembly securely.

Extension

IMPORTANT: Apply thread sealant to all pipe thread connections prior to assembly.

37. Connect the components of the extension assembly and tighten securely.
38. Screw the extension assembly into Meter Assembly (8).
 - Tighten the extension securely.

Transmission Fluid Filter

NOTE: Refer to **Figure 3** for component identification.

1. Install Filter Tube (43) into Body (42).
2. Install O-Ring (45) onto Spring and Adapter Assembly (46).
3. Install the small button of Stud (44) into the spring of the Spring and Adapter Assembly.
4. Screw the Spring and Adapter Assembly into the Body.
 - Tighten the Spring and Adapter Assembly securely.

Troubleshooting Chart

Control Valve Indications	Possible Problems	Solutions
Reduced or zero flow	<ol style="list-style-type: none"> 1. Filter Screen (34) clogged 2. Clogged system 	<ol style="list-style-type: none"> 1. Remove Filter Screen (34) and clean or replace 2. Clean or replace system filter
Continuous product flow	<ol style="list-style-type: none"> 1. Foreign material on Valve Assembly (36) 2. Valve Assembly (36) worn or damaged 	<ol style="list-style-type: none"> 1. Disassemble, clean, and inspect seat area. Check mating surfaces and replace Valve Assembly (36) as necessary. Locate and eliminate source of foreign material. 2. Replace Valve Assembly (36)
No product flow	Manual Nozzle (7) not open	Open Nozzle (7)
Leakage at Swivel Assembly (9)	<ol style="list-style-type: none"> 1. Initial tightening of Swivel Assembly (9) not sufficient 2. Seal worn or damaged 	<ol style="list-style-type: none"> 1. Tighten Swivel Assembly (9) 2. Replace Swivel Assembly (9)
Leakage at Cam (39)	Quad-Rings (38) worn or damaged.	Replace Quad-Rings (38)
Leakage at front end of Nozzle	Nozzle damaged	Replace Nozzle
Leakage at Extension Assembly	<ol style="list-style-type: none"> 1. Initial tightening not sufficient 2. Thread sealant missing or inadequate 	<ol style="list-style-type: none"> 1. Tighten leaking connection 2. Apply thread sealant* to male pipe threads
Safety on Lever Assembly (41) does not engage	Broken spring in Lever Assembly (41)	Replace Lever Assembly (41)
* Do not apply thread sealant to the first two (2) threads. Contamination can occur.		

Changes Since Last Printing

Added 3685-M

